

Power Frequency Inverters for High Voltage Tests

A. Thiede¹, F. Martin²

¹HighVolt Prüftechnik Dresden GmbH

²Universität Karlsruhe, Institut für Elektroenergiesysteme und Hochspannungstechnik
Thiede@highvolt.de, Martin@ieh.uni-karlsruhe.de

Abstract

The essential demand in high AC voltage testing is the availability of a test voltage with high quality, which is variable in amplitude and frequency. The power supply should not have any influence on the measurements – even the PD-measurement - and should be able to control a fault of the test objects insulation safely. These demands can be fulfilled using modern IGBT inverters. Two level voltage source inverters with connected resonant or filter circuits are normally used to generate a high-quality test voltage by feedback control. The properties of power frequency inverters for high voltage tests are presented in this article along with two typical circuit topologies.

1. Introduction

Investigation of the market for high voltage testing shows that the demand for power supplies with high power ratings and variable frequency exists especially for transformer testing [1], [2].

Basically a test voltage source with variable amplitude and frequency can be realized in two different ways: Using rotating frequency inverters or static frequency inverters.

Rotating frequency inverters are of the classical type. They are able to deliver the highest output power while maintaining a good test voltage quality. Additional components for reactive power compensation are often not necessary. But the poor dynamic behaviour, the efforts for maintenance and the poor availability in the market are major drawbacks. As output power demand is increased, the weight, space and the rate of needed auxiliary facilities (cooling, excitation) are also increased.

Static frequency inverters are nowadays state of the art for nearly all drive applications. High dynamic inverters advance in the area of middle

and high power. They are nearly maintenance-free and have a good availability. The generation of a high output power and a good dynamic behaviour simultaneously is difficult to work out.

When attempting to replace the rotating frequency inverters with static frequency inverters two major problems arise: the quality of the output voltage and the partial discharge noise level (PD noise level) [3].

The obligatory requirements are noted in the international standards IEC 60060-1 respectively -3 [4], [5] and for testing power transformer IEC 60076-1 [6].

The Total Harmonic Distortion (THD) is one of the most important specifications for the voltage form:

$$THD = \sqrt{\sum_{k=2}^H u_k^2} \leq 5\% . \quad (1)$$

Here $u_k = U_k / U_1$, U_k is the voltage of the k th harmonic and U_1 the voltage of the fundamental component. Frequencies up to the 7th harmonic are considered [7].

The generation of the test voltage with low THD is at very first a problem of the control system design. Output power and pulse frequency of the inverter as well as the principle structure of the feedback control system are the important factors [8].

Generally both basic inverter types generate PD noise for partly different reasons. The pulsed operation of the static frequency inverter with steep voltage pulses at the output side causes the PD noise for this type. It can be reduced by applying appropriate inverter circuit topologies and measures for filtering.

Good examples for the requirements of the PD-measurements are the conditions demanded for transformer testing. The maximum background noise level of 100 pC for the accompanying measurement during the long duration AC induced voltage test is given in 60076-3 [4]. Special

customer requirements can exceed this limit and demand 50 pC or less.

2. Voltage Source Inverter (3 phases)

Voltage source inverters (VSI) are the rife inverter-type in drive engineering. This fact as well as the small complexity of the power hardware promise economic fields of application. Using control- and modulation techniques known from drive engineering, powerful and well available control PCB's can be applied. Certainly the control of the output currents rather than the control of the output voltages plays the important role in drive engineering. It is possible to increase the output power of that inverter-type into the area of 1 MVA.

The principal structure of the voltage source inverter is depicted in Fig. 1. At first the AC input voltage is rectified, just as in the H-bridge inverter topology (see chapter 3). Input rectifier circuits, which are able to deliver higher dc-link voltages, can be applied in the area of higher output power.

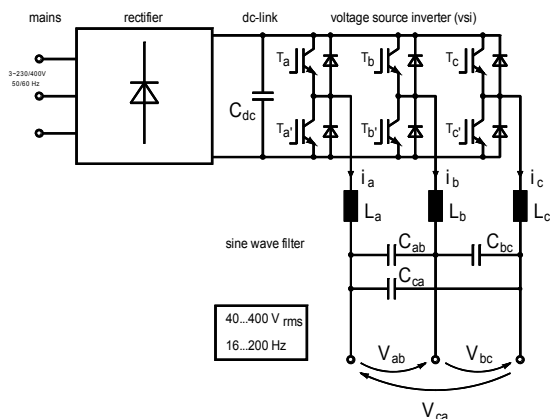

Fig. 1: Structure of the Voltage Source Inverter

The dc-link voltage is stored and smoothed with the dc-link capacitor C_{dc} . The connected two-level voltage source inverter represents the major control device. Its sine-modulated rectangular voltage pulses are supplied to the connected sine wave filter. The sine wave filter is used to filter the fundamental wave out of the voltage pulse train, which can be supplied to an adaptation transformer. Space vector modulation technique is used to control the voltage source inverter. The resulting output voltage vector will be guided in such a way, that a sinusoidal output voltage with good THD will be generated on the capacitors of the filter.

The voltage source inverter topology for the generation of test voltages with variable amplitude and frequency was tested only in the area of small output power with an experimental test setup. The measurement of a transient phase-to-phase voltage V_{ab} of a VSI with capacitive load

and with an output power of <10 kVA is shown in Fig. 2. The THD of the output voltage V_{ab} at $215 V_{RMS}$ and 50 Hz is roughly 0,9 %. The measured PD-noise level was in the same dimension as for the H-bridge inverter (Fig. 10).

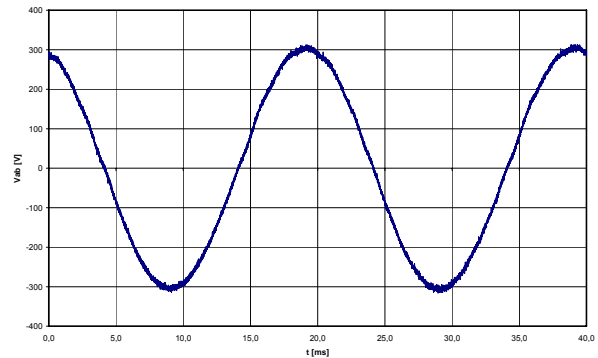

Fig. 2: Phase to Phase Voltage V_{ab} of the VSI

Previous results confirm the suitability of that inverter-type in its application as a test voltage source. The drawback of the voltage source inverter is the reduction of power in the two phase operation mode. For that reason, the H-bridge inverter topology which will be presented in the following chapter, was refined and developed to industrial maturity.

3. H-Bridge Inverter (3 x 2 phases)

Under a variety of voltage source inverters the H-Bridge inverter has proved its use in a 300 kVA type. Thus the H-Bridge is also a possibility for a 1 MVA inverter system, provided that the output current does not exceed manageable dimensions. Generating a higher dc link voltage by common multilevel inverter, e.g. diode clamp multilevel inverter (DCML) is possible to prevent this problem.

The structure for the three phase system is given in Fig. 3.

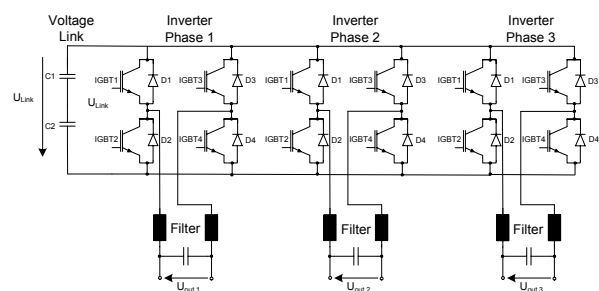

Fig. 3: Output of the Inverter with three Separate Inverter Phases.

Understanding the three phase inverter system it's important to leave the three separate one phase H-Bridge inverter. Dependent on the test - three phase or single phase test- the required sinusoidal voltage for the control can be given with or without a phase shift of 120° . Thus, apart from a normal three phase supply, an operation in par-

allel is possible and the power for a single phase test is trebled, if necessary. For the explanation of the sophisticated inverter control it's sufficient to consider the one phase system, shown in Fig. 4.

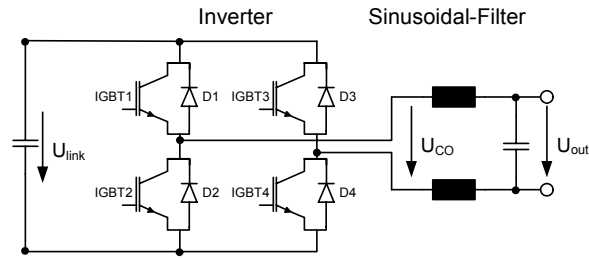

Fig. 4: Simplified Equivalent Circuit Diagram of the Inverter and Sinusoidal-Filter.

There are many possibilities to control the output voltage. It's possible to use pulse-width modulation with voltage feed-back loop. However, simulations and measurements show that this control is too slow and due to this there is no significant improvement of the output voltage. Another approach is the direct control, which switches the valves of the inverter directly on and off. This principle offers a variety of possible realizations, which have to be examined carefully. The intention of the synthesis is to develop an appropriate closed-loop control structure and a control element, which are stable and stationary correct, sufficiently damped, but also quick enough. The basic idea for the control is based on a simple setpoint / actual-value comparison applied to the output voltage and the output current (Fig. 5).

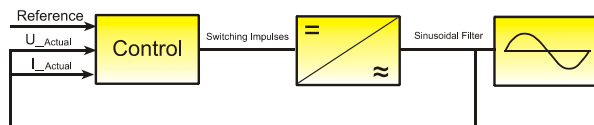

Fig. 5: Basic Concept for the Control

However, realizing this option the inverter would permanently seesaw at the output between the boundaries of the link voltage $+U_{link}$ for $U_{ref} < U_{actual}$ and $-U_{link}$ for $U_{ref} > U_{actual}$. This easy control would not be stationary correct and further more tends to oscillations and instabilities. Due to this a third possible state has to be implemented: the free-wheel-band, at which the output voltage is zero. Therefore a tolerance zone around the reference voltage has to be defined. For the enhancement of the attributes for the closed-loop control, different control structures were examined.

During simulations the cascade control, shown in Fig. 6, was proved as the best control scheme. Here the control of the output current is superimposed by the control of the output voltage. The output of the control unit consists of four logical signals $I_{negative}$, $I_{positive}$, the polarity of the current (V) and a zero band (NB).

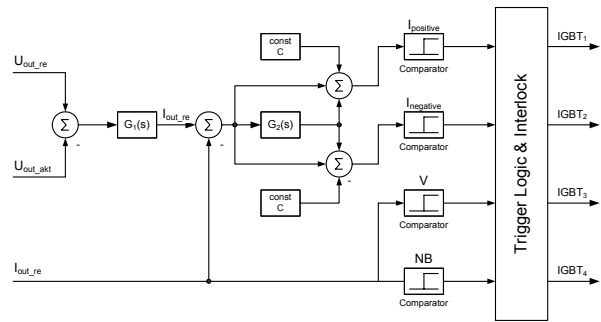

Fig. 6: Cascade Control for one Phase

Depending on the state of the signals the IGBTs of one phase of the inverter bridge have to be switched. The allocation between the possible signal combinations and possible inverter states of the inverter are realized with the help of the switching logic and interlock.

4. Results

The results during operation of the already existing 300 kVA H-Bridge inverters are promising (Figure 7). The measured THD is always smaller than 5 % and hence in compliance with the international standards.



Fig. 7: H-Bridge Inverter (300 kVA) and HMI

The following table and figures give a survey of different loads and the obtained voltage forms. Channel 1 shows the voltage and channel 2 the current form.

Table 1: Different Results during Operation

Load	2,3 Ω	2 mH	2,3 Ω + 10 μ H
Voltage	200 V	134 V	340 V
Current	83 A	215 A	69 A
THD	0,5 %	3,0 %	1,2 %
Fig. No.	7	8	9

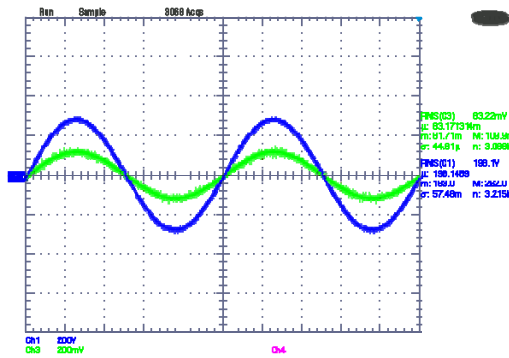

Fig. 8: Example for Ohmic Load

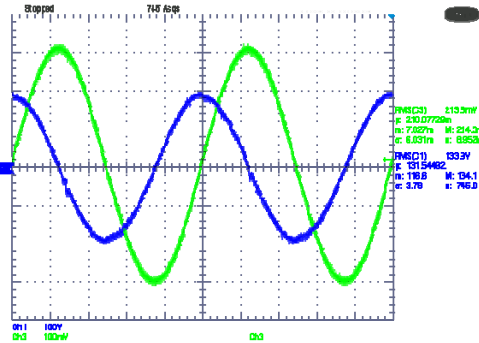

Fig. 9: Example for Inductive Load

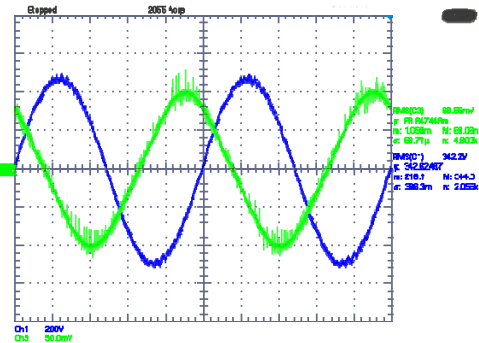

Fig. 10: Example for Ohmic-Inductive Load

A typical measurement result for the PD measurement is shown in Fig. 10. The background noise is distributed over the whole phase and hence not possible to reduce further more with the well known windowing or gating method. However the PD level independent on power and output voltage is remarkably below 50 pC which is sufficient for transformer testing.

6. Conclusion

The H-bridge-inverter and the voltage source inverter were introduced successfully as test voltage source with variable amplitude and frequency. H-bridge inverters are available now with output powers of up to 300 kVA. There is a first industrial application in the area of transformer test on-site.

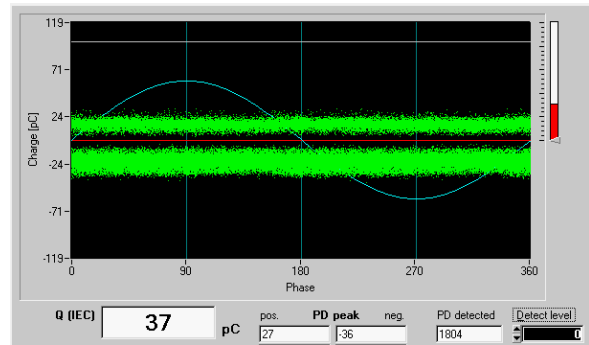

Fig. 10: Typical Background PD-Level caused by the Inverter during an Induced Voltage Test

Tests, performed with the first system confirm that the requirements on the THD of the output voltage and the PD noise level can be fulfilled. A summary of the reached technical data is given in table 2.

Table 2: Summary of Reached Technical Data

output power	300 kVA
output voltage	40...350 V _{RMS}
output frequency	16...200 Hz
pulse frequency	<10 kHz
dimensions	2405 x 2200 x 1010 mm ³
turn off delay of inverter	<10 μs
energy transfer to failure of test object	<500 J

The big advantage of the inverter technology is their excellent dynamic behaviour. Within every pulse period the quality of the output voltage will be verified and assured due to adapted actuator interventions. For this reason even output current crest factors up to three not leading to a deviation of the demanded THD of $\leq 5\%$. In the case of an insulation fault of the test object the good dynamics allows furthermore a very fast turn off of the inverter ($\leq 10 \mu s$) and a small energy transfer into the failure (<500 J). Also the mechanical design of the inverter is compact and advantageously. All main and auxiliary components needed for the generation of the variable test voltage are housed in one cubicle (even feeding and cooling units). Studies have shown, that for quadruplicating the output power only an increase of the inverter cubicle volume of 30% to 40% will be necessary. Inverter systems with an output power of up to 1 MVA are planned.

7. References

- [1] P. Werle, J. Wohlfahrth, K. Scheil, M. Vogel und M. Steiger "Reperaturen und Hochspannungsprüfungen von Leistungstransformatoren vor Ort." ETG FB 104, Kassel, 2006
- [2] U. Thieß, V. Lanzl, K. Vaterrodt, R. Plath "Vor-Ort-Reparaturen und Vor-Ort-Prüfungen an HGÜ-Transformatoren in Carora Bassa, Mosambik." ETG FB 104, Kassel, 2006
- [3] W. Hauschild, A. Thiede, T. Leibfried, F. Martin "Statische Umrichter für Hochspannungsprüfungen an Leistungstransformatoren" *Stuttgarter Hochspannungssymposium 2006*, Stuttgart, 2006, pp. 371-380
- [4] IEC 60060-1 "High-voltage test techniques. Part 1: General definitions and test requirements" 11/1989
- [5] IEC 60060-3 "High-voltage test techniques - Part 3: Definitions and requirements for on-site testing" 02/2006
- [6] IEC 60076-1 "Corrigendum 1 - Power transformers - Part 1: General" 06/1997
- [7] IEC 60076-3 "Power Transformers - Part 3: Insulation levels, dielectric tests and external clearances in air" p. 19, 03/2000
- [8] F. Martin, T. Leibfried "An universal high-voltage source based on a static frequency converter" ISEI 2006, Conference, Toronto, 2006, pp. 420-423

Kurzfassung:

Die zentrale Problemstellung der Hochspannungsprüftechnik ist die Bereitstellung einer amplituden- und frequenzvariablen Prüfspannung hoher Qualität. Die Prüfspannungsquelle darf die Messungen nicht beeinträchtigen und muss das Versagen der Prüflingsisolation sicher beherrschen. Diese Anforderungen können durch moderne IGBT-Wechselrichter erfüllt werden. In der Regel kommen dabei Zweipunkt-Wechselrichter mit Spannungszwischenkreis zum Einsatz, die die Prüfspannung mit nachgeschalteten Resonanz- oder Filterkreisen erzeugen. Im Beitrag werden die Anforderungen an Wechselrichter großer Leistung für Hochspannungsprüfungen systematisiert und zwei typische Schaltungstopologien vorgestellt.

Anschrift:

Andreas Thiede
HIGHVOLT Prüftechnik Dresden GmbH
Marie-Curie-Straße 10
01139 Dresden
Tel.: 0351-8425663
Fax: 0351-8425610
e-mail: Thiede@highvolt.de

Florian Martin
Institut für Elektroenergiesysteme und Hochspannungstechnik (IEH) Universität Karlsruhe
Engesserstrasse 11
76131 Karlsruhe
Tel.: 0721-6083065
Fax: 0721-691776
e-mail: Martin@ieh.uni-karlsruhe.de