

The electrical strength of transformer oil in a transformerboard-oil system during moisture non-equilibrium

B. Buerschaper, O. Kleboth-Lugova and T. Leibfried

Institute of Electrical Energy Systems and High-Voltage Technology, University of Karlsruhe, Germany

Abstract: The operational reliability of power transformers depends primarily on the oil-transformerboard condition. It's well known, that the presence of moisture has significant influence on ageing of transformerboard and also on the dielectric strength of transformer oil. At constant temperature a moisture equilibrium between oil and transformerboard exists. The change of load conditions causes a change of temperature and as a result a migration of moisture between oil and transformerboard. These interactions are very important for the breakdown phenomena in oil-cellulose insulation. The disturbance of moisture equilibrium results in a significant reduction of the electrical strength of the oil, especially if the transformerboard has a water content more than 2.5%. This value is normally in an ageing transformer. The experimental investigations of the electrical strength of transformer oil during moisture non-equilibrium are presented. The transition conditions are simulated in an indirectly heated test setup, which represents the insulation system of a power transformer. This model has the same oil-transformerboard ratio (volume and surface area) as a real 200 MVA transformer. The parameters, having the main influence of the breakdown-voltage during the non-equilibrium state, are discussed.

Introduction

Monitoring of high-voltage power transformer is becoming more and more important. On the one hand the operating time of transformers should be maximized. On the other hand early failure detection has the same importance in avoiding malfunction or breakdown. There are a lot of approvals of diagnostic procedures to achieve this. By means of evaluation e.g. of electrical strength, quantity of pulp (suspended solids) and gas analysis of insulating oil in a laboratory a good long time monitoring can be realized. Other important monitoring procedures are PD-measurement, online gas-in-oil analysis, continuous voltage monitoring of AC and transient voltages and temperature control at significant points of the transformer. In total this gives real control of the momentary condition of a transformer. In the ideal case sources of errors should not only be detected, but also

be located. The goal of presented research is to advance existing measuring methods and, if necessary, to establish new ones.

In the following new investigations about the moisture transition of the transformerboard-oil system and its influence on electrical strength of the transformer oil are presented.

Interaction between oil and transformerboard in power transformers

Power transformers possess two dielectrics: insulating oil and transformerboard. Transformerboard has a strong hygroscopic effect. Both dielectrics have a strong moisture interactivity. In a new transformer the water content is low. The insulating oil has a water content as low as only 5ppm and in transformerboard about 0.5% (both at 20°C oil temperature). The water content in the transformerboard changes over the life cycle. The two main reasons are:

1. moisture interactivity with environment
2. additional moisture generation due to chemical reactions (inherent process)

At constant temperature there is always a moisture equilibrium between the insulating oil and the transformerboard. The moisture equilibrium is attained, if relative moisture in oil and transformerboard are the same. The relative moisture can be calculated as (1)

$$W_{rel} = \frac{W_{abs}}{W_{Sat}} \quad W_{Sat} = f(T) \quad (1)$$

where W_{sat} - saturation of moisture is a function of temperature.

W_{rel} - relative moisture

W_{abs} - water content

A rising or falling temperature from T_1 to T_2 causes the changing of the relative moisture in both dielectrics until a new equilibrium will be reached. This process is called transition period in the non equilibrium. Below, the behaviour of insulating oil in regard to its dielectric strength in the non equilibrium has been described.

Present Experience

There are only a few publications, which deal with the problems of non-equilibrium between transformerboard and insulating oil in the transition period [1-3].

Investigation of moisture transition

Consideration of experimental setup

In our investigations the parameters of water content in oil and transformerboard, as well as the dielectric strength of oil are of interest. For different initial moistures of transformerboard these parameters have to be investigated to determine their interdependence.

To realize the investigations and experiments close to reality, a scale model was designed with the same oil-transformerboard surface area- and volume ratio as that one of a 200 MVA transformer. The experiments have been conducted with 2.7 dm³ of transformerboard T IV of 3 mm thickness in a oil container having a volume of 21 dm³.

To measure the dielectric strength of insulating oil, spherical electrodes (IEC156) were integrated in the model. The applied AC test voltage was in accordance to the same IEC-Norms (50Hz/2kVs⁻¹). The measurement of the oil temperature has been realized with a sensitive Pt100-Sensor ($\pm 0.05^\circ\text{C}$ accuracy). The moisture of oil and transformerboard was measured by the Karl Fischer method.

Experimental setup

The experimental setup is shown in Figure 1.

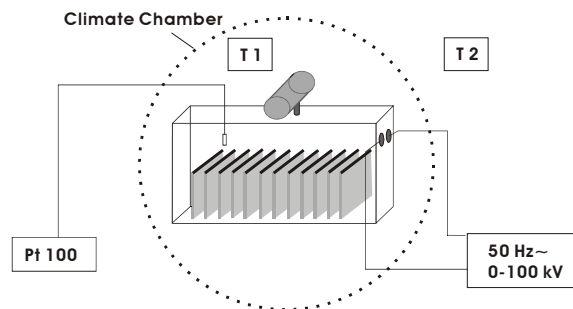

Figure 1: Experimental setup for investigation of moisture transition

The heating of the scale model was realized by indirect heating in a climate chamber. To cool the model, it was exposed to the low ambient temperature. The ambient temperature determines the cooling gradient.

Moisturisation of transformerboard

The defined moisturisation of transformerboard for three test series with initially moistures of 0.5%, 2% and

3.5% is of importance and should be described here briefly. Using these three initial moistures of the transformerboard, the different ageing states of a transformer are intended to be simulated. The transformerboard moisture of 0.5% corresponds to a new transformer and 3.5% to a transformer, which was in service for a long time.

The moisturisation of transformerboard under climatic exposure and especially the subsequent conditioning of the complete insulation system have a major influence on accuracy and reproducibility of measurement results. The moisturisation procedure and parameters are described in [4]. After moisturisation, the transformerboard was placed in the scaled model.

Initially, the complete insulating oil-transformerboard system must be conditioned, because the dispersion of relative large water drops must be as fine as possible. To do that, the transformer model must be exposed to a heating cycle up to 60-70°C for 48 hour and after this for self cooling-down to room temperature. This should be repeated many times, but not less than five times.

Results of the investigation

The electrical strength of oil during the moisture transition in oil-transformerboard system was the main object of the research. For three defined moisture contents of the transformerboard samples water content and breakdown voltage in oil during the moisture equilibrium and during moisture transition have been determined. The record of temperature transition in a real 200MVA transformer (Figure 2) has been simulated in the scale transformerboard-oil model.

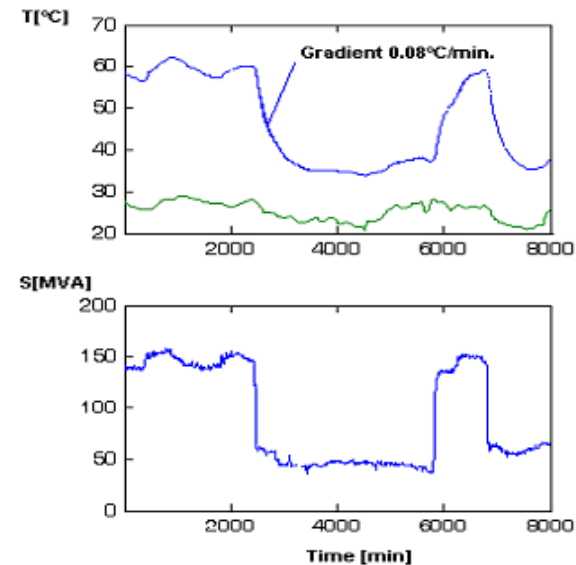

Figure 2: The record of temperature and power in a real 200 MVA-power transformer

Moisture transition during non equilibrium

The time-dependence of the temperature and the water content in oil is given in Fig. 3.

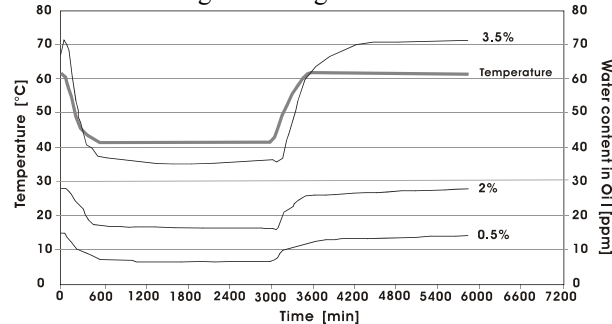

Figure 3: Temperature and water content in oil for initial moisture content of 0.5%, 2% and 3.5% in transformerboard

The water content in oil depends on the initial moisture of the transformerboard samples. As it can be seen, during the cooling-down phase the water content in the oil varies almost as fast as the changing of the temperature. In contrast, during warming-up phase the water content in oil varies slower than the temperature of the oil. The water content increases within 24 hours, though the temperature of oil is staying constant. That means, the process of water exchange in the direction from oil to the transformerboard is faster than that one from transformerboard to oil.

Breakdown voltage during non-equilibrium

The behaviour of the breakdown voltage in oil during changing of the temperature was a matter of particular interest. The measured breakdown voltages are illustrated in Figure 4. Every shown voltage value was calculated from 6 single breakdown voltage values.

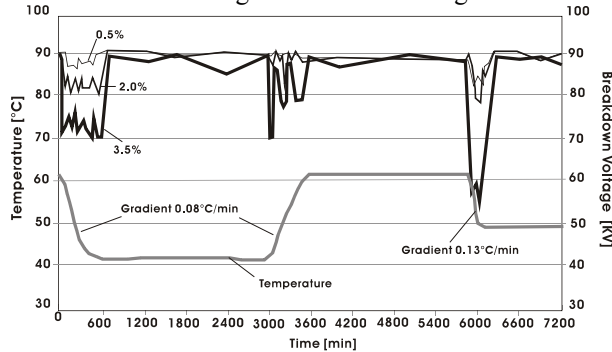

Figure 4: Temperature and breakdown voltage in oil for different temperature gradients

The breakdown characteristics depend on 4 parameters:
 initial moisture of the transformerboard
 initial temperature
 temperature gradient
 positive or negative temperature gradient

The higher the water content of transformerboard, the lower the average value of the breakdown voltage in oil during the transition process is. This fact is obvious, because by the higher initial moisture content of the transformerboard the water content in insulating oil increases (Fig. 3). Indeed, for initial moisture contents of transformerboard higher than 2% a significant decrease of the breakdown voltage is observed. For initial moisture contents less than 2% the breakdown voltage in oil is very high (>85kV).

The changing of the breakdown voltage depends on the initial temperature of the system at the beginning of the cooling-down or warming-up phases. In pre-tests it was found that at 60°C initial temperature (cooling-down phase) and at 40°C (warming-up phase) the sensitivity in regard to breakdown characteristics is the highest. All experiments have been carried out in the temperature range from 40°C to 60°C, because these temperatures are the operating oil temperatures in a transformer. The temperature gradient plays an important role in this process. The higher the gradient, the more the breakdown voltage decreases (Figure 5-6).

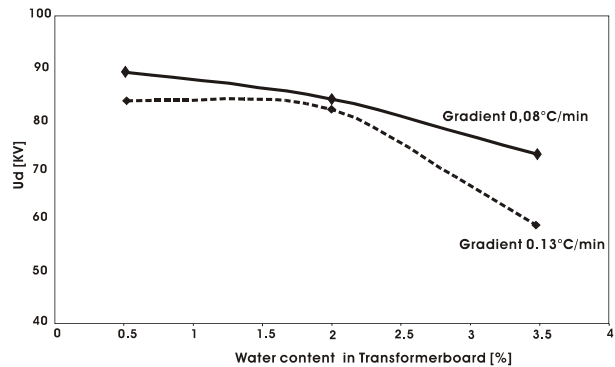

Figure 5: Breakdown voltage in oil against initial moisture content in transformerboard for temperature gradients of 0.08 and 0.13°C/min during cooling-down phase

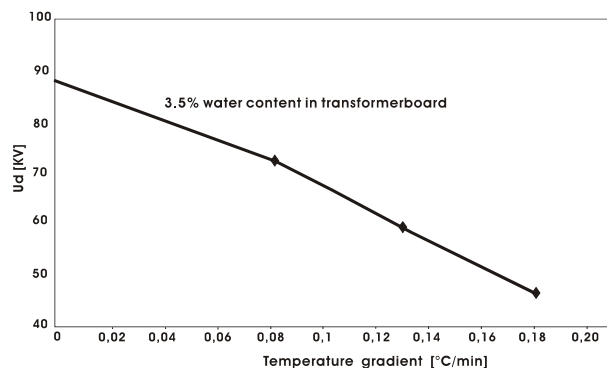

Figure 6: Breakdown voltage in oil against temperature gradient during cooling-down phase for initial moisture content of 3.5% in transformerboard

This conclusion refers only to the cooling-down phase. Its behavior can be explained in the following way. During the cooling-down phase the transformerboard can absorb only a limited amount of water from oil per time unit. The relative water content in oil increases and that's why the breakdown voltage decreases.

The comparison of the breakdown voltages with identical values of the positive and negative temperature gradients shows that the sensitivity of the breakdown voltage during the cooling-down phase is higher than during the warming-up phase. What's the reason of that fact? As above mentioned during the warming-up phase water migrates slower from the transformerboard into oil. Since the temperature is constant, within 24 hours the process of water exchange has been completed. Thereby, during the warming-up phase the moisture transition isn't so distinct as one during the cooling-down phase. That fact is being reflected in the electrical strength of the oil.

Conclusion

The results of the investigations have confirmed the reduction of breakdown voltage in transformer oil during moisture transition from transformerboard to oil or vice versa. The electrical strength depends mainly on the water content in transformerboard and the gradient of temperature. At the warming-up phase the breakdown voltage has another characteristics than in the cooling-down phase. A significant reduction of the electrical strength of transformer oil was measured only at water contents higher than 2% in the transformerboard.

Currently, we investigate the possibility, to use the breakdown voltage as an indicator for water content in transformerboard.

References

- [1] C. Krause, H. P. Gasser, J. Huser and A. Sidler, "Effects of moisture in Transformerboard Insulation and the Mechanism of Oil Impregnation of Void," *Transform 98*, Munich, Germany, April 20-21 st 1998.
- [2] V. V. Sokolov, Z. Berler and V. Rashkes, "Effective Methods of the Assessment of the Insulation System Conditions in Power Transformers: A View Based on Practical Experience," *Proceeding of the EIC/EMCWE'99 Conference*, October 26-28, 1999, Cincinnati, OH.
- [3] Y. Du, M. Zahn, B.C. Lesieutre and A.V. Mamishev, "Moisture equilibrium in transformer oil paper systems", *IEEE Electrical Insulation*, Vol. 15, No.1, Jan-Feb 1999, pp. 11-20.
- [4] C. Krause, "Compendium", A 40, Weidmann Systems International AG, 2001.

Author address: B. Buerschaper, Institute of Electric Energy Systems and High-Voltage Technology, University of Karlsruhe, Kaiserstr. 12, 76128 Karlsruhe, Germany, Email: buerschaper@ieh.uni-karlsruhe.de